

Two and Three Step Controllers

CAPACITOR SWITCHING CONTROLLERS

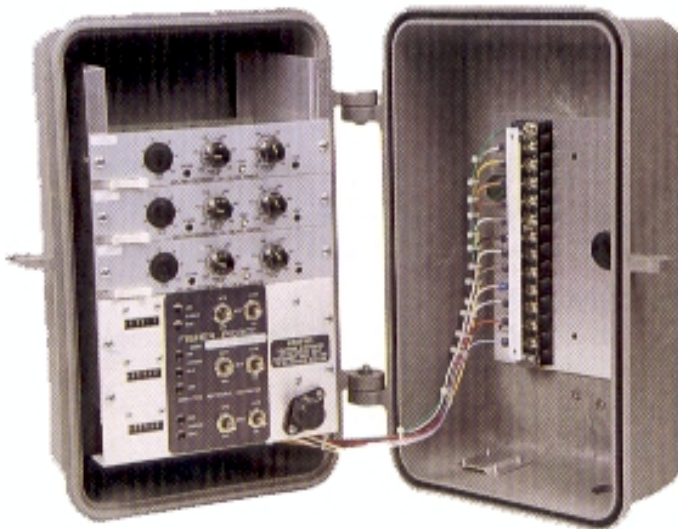

Multi-Step Controller



Voltage Module



Series 1301 Current Sensor

- Plug-in modules for user configuration.
- Field-proven, weatherproof (NEMA 3) (structural) foam or welded aluminum enclosures.
- Automatic-manual switches, operations counter, spare fuse and three stages of surge protection.
- Accessible I/O test jacks on main panel.
- High torque, vibration-resistant adjustment knobs.
- Standard line current sensing inputs: Fisher Pierce 1301 line post sensor and AT929 underground/padmount sensor or a C.T.

These modular controllers offer the most flexible and efficient method of capacitor switching.

Fisher Pierce has over forty years of experience manufacturing capacitor controllers.

Note: See 4400/4500 data sheets for programmable multi-function single step controllers.

DESCRIPTION OF OPERATION

The Fisher Pierce Multi-Step Series Control is intended for use with multiple capacitor racks, typically found in substation applications. The controls can be purchased in either 2 or 3 step configurations. They are available in Var, Voltage or Line Current configurations.

The control will operate (close) starting with the first step (top module) then activate the second and third (if purchased) after a fixed time delay. This ensures proper sequencing on capacitors. When opening capacitors, the sequence is reversed.

ORDERING INFORMATION FOR MULTI-STEP CONTROLLERS

TO ORDER: FOLLOW THE MODEL NUMBER EXAMPLES AS SHOWN, THEN SELECT FROM THE TABLES NUMBERED 1 THROUGH 8

Multi-step controllers are available with fixed time delay only. 60 and 20 seconds standard.

MODEL NUMBER ORDERING GUIDE

TWO STEP MODULE NUMBER SYSTEM

Example: Voltage Control

TABLE	1	3	2	3	4	5	6	7	8
	2406	D	35	D	W	J	6	6	B

THREE STEP MODULE NUMBER SYSTEM

Example: Voltage Control

TABLE	1	3	2	3	2	3	4	5	6	7	8
	2406	D	35	D	35	D	W	J	6	6	B

TABLE 1. FIRST STEP

Code	TYPE
2406	Voltage
4604*	VAR, use Fisher Pierce Series 1301 standard line post sensor, 3 ϕ , 4W, Wye system
4608	VAR, use 5A C.T. 3 ϕ , 4W, Wye system
4609	VAR, use 5A C.T. 3 ϕ , 3W, Delta system
4620	VAR, use Fisher Pierce Series 1301 high accuracy line post sensor, 3 ϕ , 4W, Wye system
4844	Line current, use Fisher Pierce Series 1301 standard or high accuracy line post sensor
4846	Line current, use 5A C.T.

TABLE 2. SECOND AND/OR THIRD STEP

Code	DESCRIPTION
35	Voltage
36	Line current, use with 4844
37	Line current, use with 4846
38	VAR, use with 4604
39	VAR, use with 4608
40	VAR, use with 4609
64	VAR, use with 4620

TABLE 3. TIME DELAY

Code	TIME
D	60 seconds (standard)
B	20 seconds (standard)

TABLE 4. MOUNTING CONFIGURATION*

Code	DESCRIPTION
W	Flat wall bracket
B	Wrap-around pole bracket

TABLE 5. EXTERNAL WIRING CONNECTIONS

Code	DESCRIPTION
J	12 terminal wiring strip

Terminal Strip (Step Controls Only)

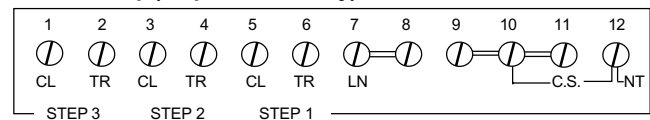

JUMPER CONNECTIONS:

- isolated Output, no jumper 7 to 8 (term 8 = switching voltage)

TABLE 6. ENCLOSURE*

Code	DESCRIPTION
3	Aluminum, 8" w x 7" d x 18h"
6	Structural foam, 9.25" w x 8.5" d x 15.25" h
2	None

TABLE 7. OPERATING INFORMATION

Code	DESCRIPTION
3	240V, 50Hz, 5A fuse
5	120V, 50Hz, 5A fuse
6	120V, 60Hz, 5A fuse
8	120V, 60Hz, 10A fuse

TABLE 8. MODEL GENERATION

Code	DESCRIPTION
B	Step Controller

- Consult factory for additional options.

*MOUNTING CONFIGURATIONS

Refer to page 4.

SPECIFICATIONS FOR MULTI-STEP CONTROLLERS

Input Voltage Range: 105 to 135Vac, 60 Hz
200 to 260 Vac, 50 Hz

Output Rating SPDT: 120 Vac, 10A; 50A, 50% PF or
100A, 6 cycles make only

HiPot Test: 1800 Vac, 1 second. ANSI C62.41 1974

Operating Temperature: -30^o to + 60^oC
-22^o to + 140^oF

Close Counter: Pulse operated. All close operations

Current Sensors: FP Series 1301.
Or 0 - 5A C.T.

Time Delays: +/- 10%: 20 or 60 seconds

Surge Protection:

120 Vac Input: 8450pkA minimum. 800 Vac maximum
clamp, 160 joules

Current Sensor: 1000pkA. 200 Vac maximum clamp.
30 joules

Enclosures: Structural foam, 15.25"h x 9.25"w x 8.5"d.
Aluminum, 18"h x 8"w x 7"d. Available with wall, pole,
or 4/6 stab meter plug

SENSING MODULES

Type	Input	Range	Accuracy
Voltage	V.T.	105-135 Vac	+/- 1 Vac
Current	1301 Ser.	3-500 Aac	+/- 3% setting +/- 3% range
Current	C.T.	0.5-5Aac	+/- 3% Setting +/- 3% Range
VAr	1301 Ser.	0-300 A lag 0-450 A lead	+/- 3% setting +/- 3% range
VAr	C.T.	0-1 A reactive 0.5 Amp (lead/lag)	+/- 5% range

STEP CONTROL DRAWING

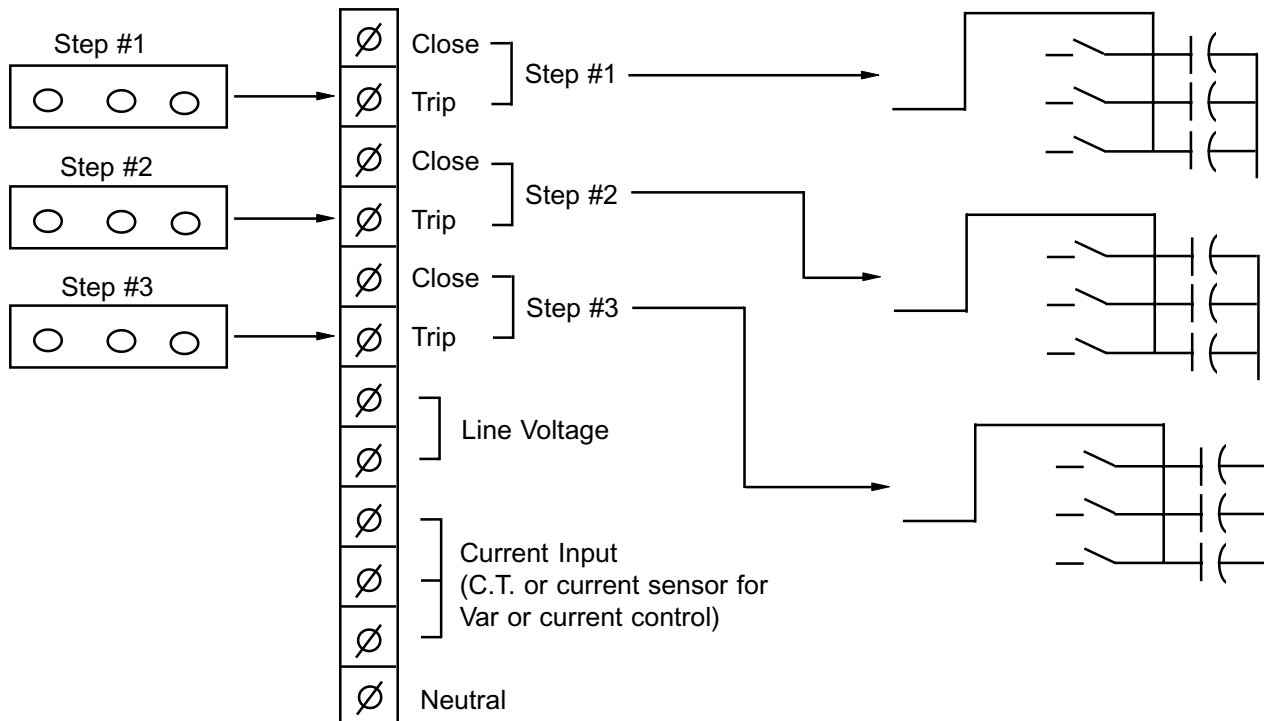

MECHANICAL DATA

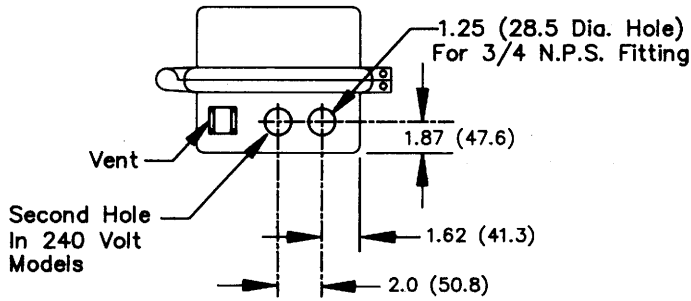
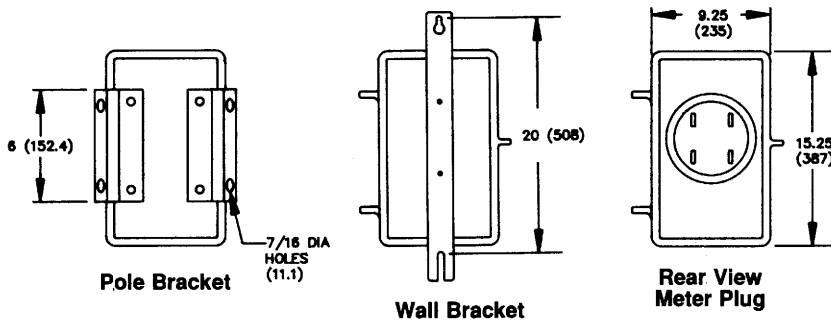

Structural Foam Enclosure

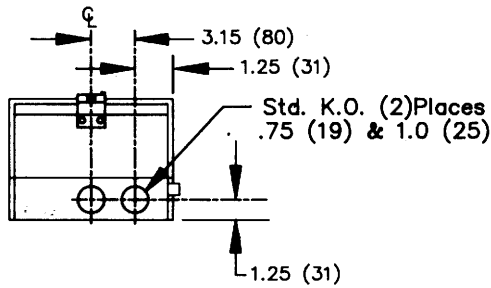
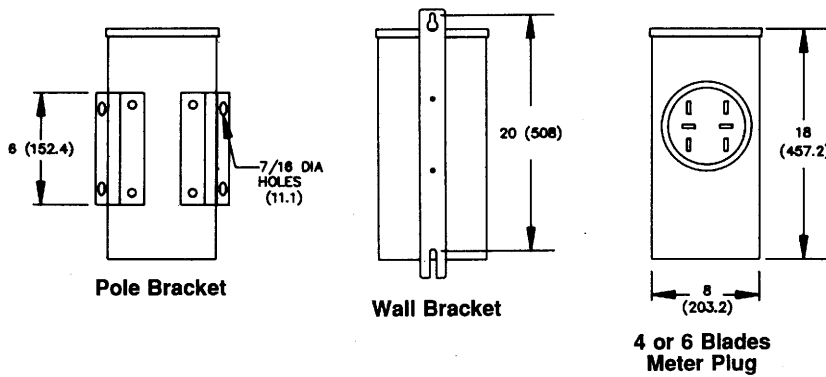

Aluminum Enclosure

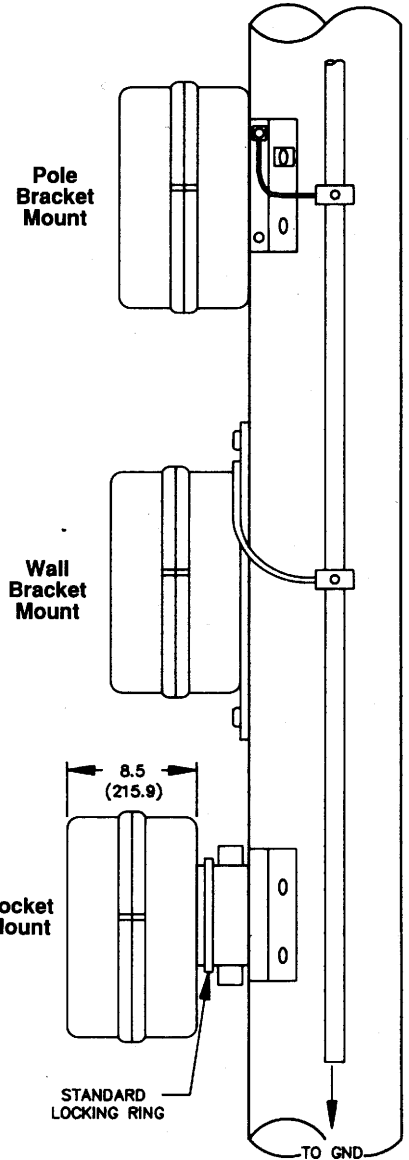

90 Libbey Parkway, Weymouth, MA 02189 U.S.A.
Tel: (781) 340-0700 • Fax: (781) 340-0728
www.fisherperce.com



4000 East 116th St., Cleveland, Ohio 44105-4398 USA
Tel: (216) 271-6600 • Fax: (216) 341-3615
www.joslynhivoltage.com

1560 55th Avenue, Lachine, Quebec, Canada H8T 3J5
(514) 631-6145 • Fax (514) 631-1215